

CONVEYING SOLUTIONS

Product Overview

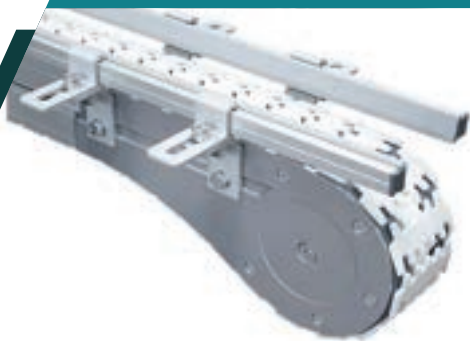

INDEX

Sr.No	Types Of Conveyors	Page No.
01	Pallet Transfer Conveyor System	01
02	PTS1 & PTS1/H Pallet Conveyor	02
03	PTS2 & PTS2/L Pallet Conveyor	03
04	PTS4 & PTS5 Pallet Conveyor	04
05	Pallet Transfer System - Overview	05/06
06	Flexible Chain Conveyor - Overview	07/08
07	Flexible Chain Conveyor System	09
08	Modular Belt Conveyor System	10
09	Endless Belt Conveyor System	11
10	Powered Roller Conveyor System	12



ABOUT US

iConMov brings over 20 years of experience concerning Industrial Automation through the execution of numerous industrial projects including engineering, manufacturing, testing, erection, commissioning, and life cycle services. With hundreds of delivered conveyors in the past and an intent to cater to the ever-demanding needs of industry for High Efficiency and Precise Positioning Material Transfer, the founders of iConMov decided to start a

CONVEYOR ONLY COMPANY.

iConMov will be supplying the best quality Conveyor Systems, Pallet Transfer Systems, Modular Belt Conveyors & Powered Roller Conveyors. The objective is to be the most preferred supplier of Conveyors and Pallet Transfer Systems in India. With a specialized team of Design and Application Engineers and rich experience in catering to all major industry segments like Food, Pharma, Automobile, and Engineering, we will strive to make our mark as a specialized conveyor manufacturer. Based on our experience in different material behavior, we have developed our technology to meet our customer's highest requirements. We believe each application can be unique and therefore we design each conveyor with the same vigor, enthusiasm, passion & precision as the first one all those years back.

iConMov Technologies Pvt Ltd



✉ sales1@iconmov.in
sales2@iconmov.in

📍 Plot no-37, GAT no-714, Jayawant Industrial Estate,
Pune-Bangalore Highway, Pune-412206

iConMov Pallet Transfer conveyor system (PTS) is composed of PTS1, PTS1/H, PTS2, PTS4 and PTS5 which differ in sizes & permissible load capacities. The Pallet Transfer system consist of standardized components which can be seamlessly assembled with other units to convey for specific production requirements. The PTS system offers economical conveying solutions that can be scaled as needed for almost any application. All systems are designed for modular assembly.

Overview

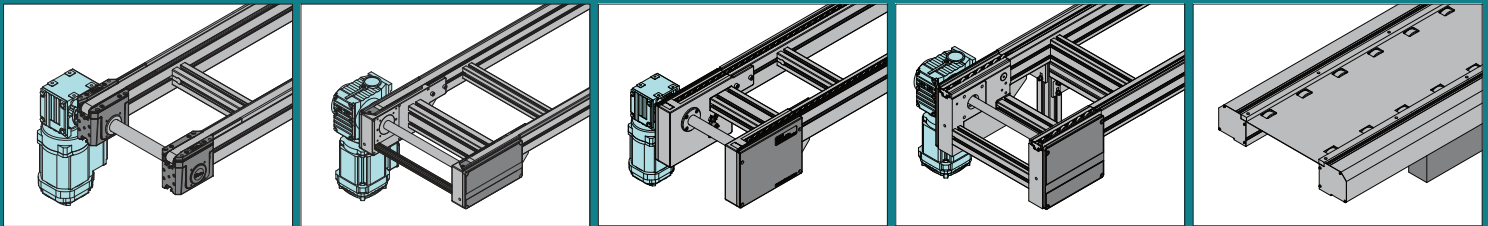

PTS1

PTS1/H

PTS2

PTS4

PTS5

Conveyor Parameter

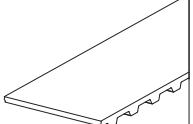
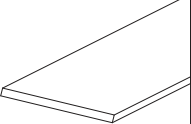
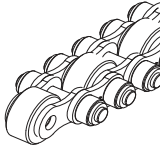
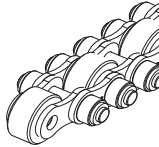
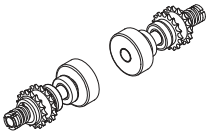
Conveyor Type	PTS1	PTS1/H	PTS2	PTS4	PTS5
Key Parameter					
Conveying Medium			08BS 	12BS 	
Max. Unit Load Capacity	1 kg/cm	1 kg/cm	1.5 kg/cm (PA) 2.0 kg/cm (ST)	4.0 kg/cm	200 kg for each pair of rollers 200 kg
Max. Total Load Capacity	60 kg	150 kg	1200 kg (PA) 2200 kg (ST)	3000 kg	4500 kg

Conveyor Typical Application

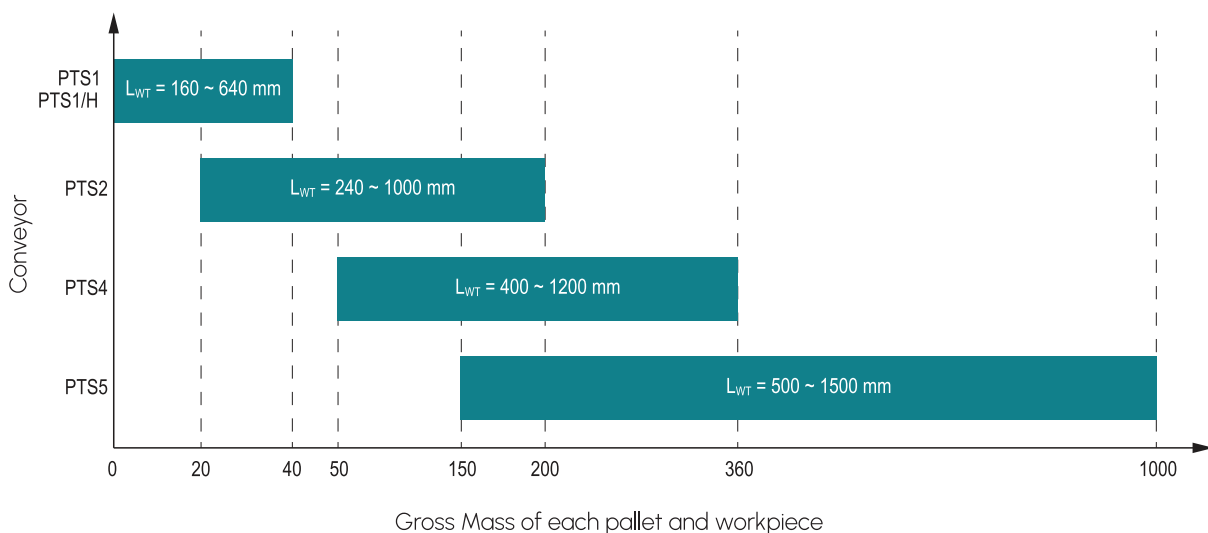

■ PTS1 Pallet Conveyor (End Drive/Center Drive)

End Drive

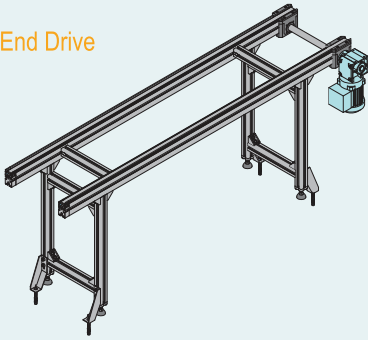

Center Drive



SPECIFICATION

Conveyor Length	$400 \leq L \leq 6000$ mm
Pallet Width	$160 \leq B_{WT} \leq 1200$ mm
Conveyor Height	Customer Specified
Max. Load Capacity	60 kg
Max. Conveyor Speed	$V \text{ max.} = 20$ m/min
Drive Model	Direct
Conveying Medium	Special toothed belt

FEATURES/BENEFITS

1. Modular design, part production in mold, easy to assemble and maintain.
2. Due to its modular components, it can be adapted to suit specific production conditions and in conjunction with specific units including rotate unit, curve, lift and transverse unit and lift unit.
3. T slot aluminum profile frame for easy accessory attachment (sensor, bracket etc).
4. Conveying medium is antistatic toothed belt.

INDUSTRIES SERVED

- Factory Automation
- Electronics
- Automobile Parts

■ PTS1/H Pallet Conveyor

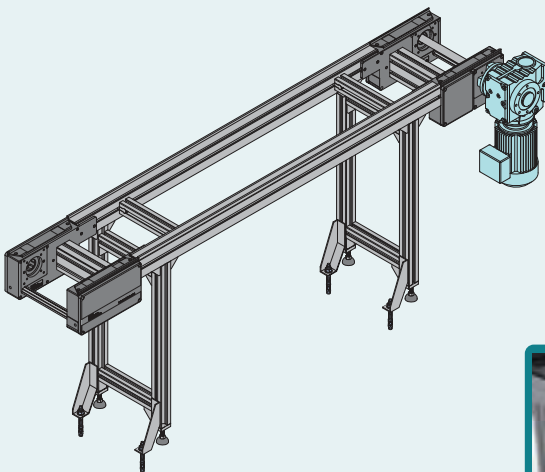

SPECIFICATION

Conveyor Length	$1200 \leq L \leq 12000$ mm
Pallet Width	$160 \leq B_{WT} \leq 1200$ mm
Conveyor Height	Customer Specified
Max. Load Capacity	150kg
Max. Conveyor Speed	$V \text{ max.} = 20$ m/min
Drive Model	Direct
Conveying Medium	Special toothed belt

FEATURES/BENEFITS

1. Modular design, part production in mold, easy to assemble and maintain.
2. Due to its modular components, it can be adapted to suit specific production conditions and in conjunction with specific units including rotate unit, curve, lift and transverse unit and lift unit.
3. T slot aluminum profile frame for easy accessory attachment (sensor, bracket etc).
4. Conveying medium is antistatic toothed belt.

INDUSTRIES SERVED

- Factory Automation
- Electronics
- Automobile Parts

PTS2 Pallet Conveyor

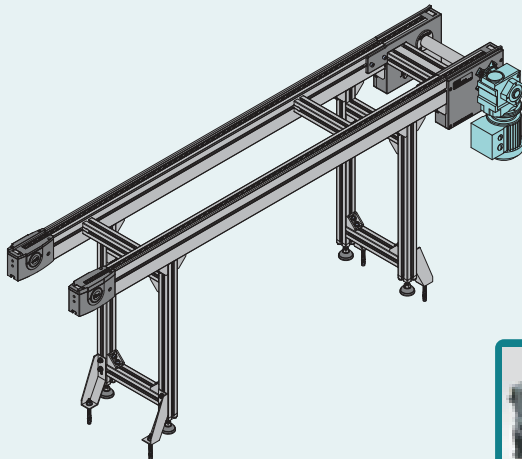

SPECIFICATION

Conveyor Length	$600 \leq L \leq 12000\text{mm}$
Pallet Width	$160 \leq B_{WT} \leq 1200\text{ mm}$
Conveyor Height	Customer Specified
Max. Load Capacity	OP, OS=2200Kg IP, IS=800Kg
Max. Conveyor Speed	V max. = 20 m/min
Drive Model	Direct
Conveying Medium	08BS Accumulation Chain 08BS

FEATURES/BENEFITS

1. Modular design, part production in mold, easy to assemble and maintain. For medium and high load conveying.
2. Due to its modular components, it can be adapted to suit specific production conditions and in conjunction with specific units including rotate unit, curve, lift and transverse unit and lift unit.
3. T slot aluminum profile frame for easy accessory attachment (sensor, bracket etc).
4. Conveying medium is antistatic toothed belt.

INDUSTRIES SERVED

- Factory Automation
- Home Appliance
- Electronics
- Automobile Parts

PTS2/L Pallet Conveyor

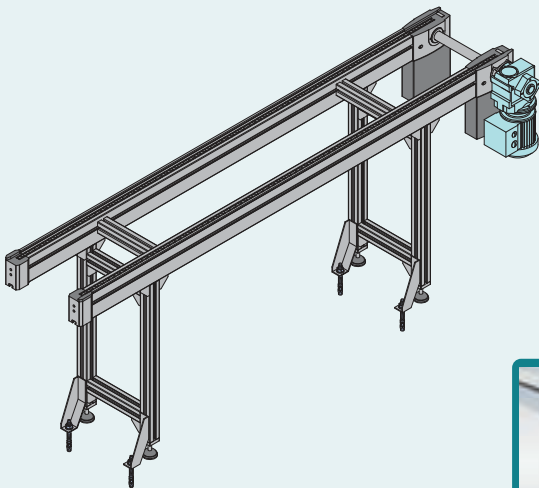

SPECIFICATION

Conveyor Length	$600 \leq L \leq 12000\text{mm}$
Pallet Width	$160 \leq B_{WT} \leq 1200\text{ mm}$
Conveyor Height	Customer Specified
Max. Load Capacity	700kg
Max. Conveyor Speed	V max. = 20 m/min
Drive Model	Direct
Conveying Medium	08BS Accumulation Chain 08BS

FEATURES/BENEFITS

1. Modular design, part production in mold, easy to assemble and maintain. For medium and high load conveying.
2. Due to its modular components, it can be adapted to suit specific production conditions and in conjunction with specific units including rotate unit, curve, lift and transverse unit and lift unit.
3. T slot aluminum profile frame for easy accessory attachment (sensor, bracket etc).
4. Conveying medium is antistatic toothed belt.

INDUSTRIES SERVED

- Factory Automation
- Home Appliance
- Electronics
- Automobile Parts

PTS4 Pallet Conveyor

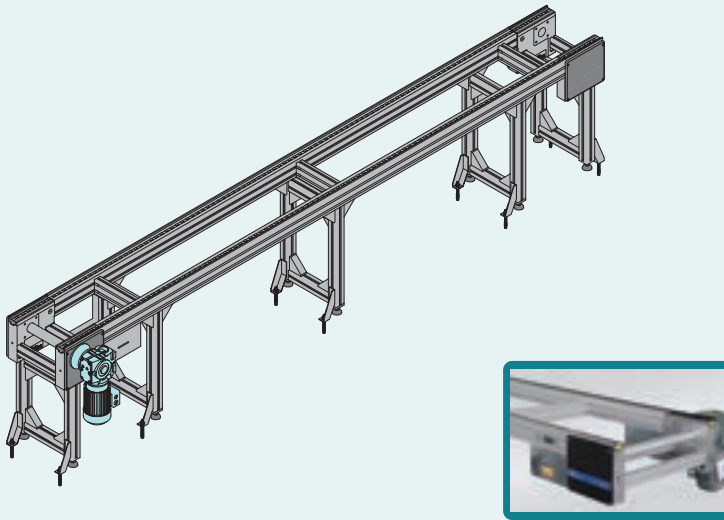

SPECIFICATION

Conveyor Length	$1000 \leq L \leq 20000$ mm
Pallet Width	$400 \leq B_{WT} \leq 1600$ mm
Conveyor Height	Customer Specified
Max. Load Capacity	OP, OS=3000Kg IP, IS=1500Kg
Max. Conveyor Speed	V max. = 20 m/min
Conveying Medium	12BS Accumulation Chain 12BS

FEATURES/BENEFITS

1. Modular design, good appearance, easy to assemble and maintain.
2. Applicable for heavy duty pallet. The pallet can be located and accumulated.
3. T slot aluminum profile frame for easy accessory attachment(sensor, bracket etc).
4. It can be used in conjunction with specific units including rotate unit, lift and transverse unit and lift unit for flexible automatic control.

INDUSTRIES SERVED

- Factory Automation
- Automobile Parts
- Home Appliances
- Electronics

PTS5 Pallet Conveyor

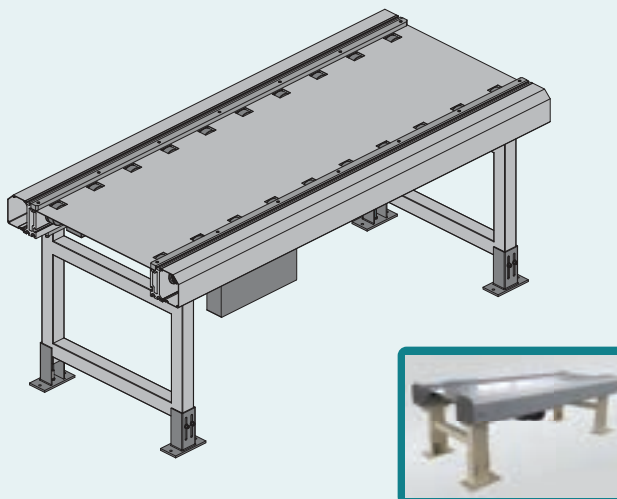

SPECIFICATION

Conveyor Length	$1000 \leq L \leq 6000$ mm
Pallet Width	$300 \leq B_{WT} \leq 1200$ mm
Conveyor Height	Customer Specified
Max. Load Capacity	4000 kg
Max. Conveyor Speed	V max. = 15 m/min
Drive Medium	Chain
Conveying Medium	Roller
Roller Spacing	158/196/247

FEATURES/BENEFITS

1. Modular design of standard unit (recommended length of standard unit is 1905 mm, 1968 mm and 1981 mm respectively according to different roller spacing.)
2. Suitable for heavy load pallet conveying which can achieve flexible control.
3. In conjunction with rotate unit and lift transverse unit to achieve automation cycle control.

INDUSTRIES SERVED

- Automatic assembly detection production line
- Automotive engine
- Transmission assembly line
- Circuit breaker

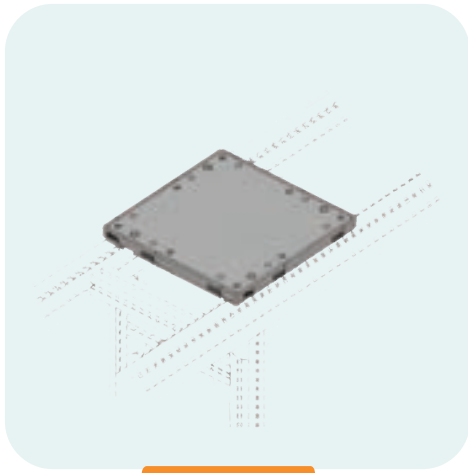

PALLET

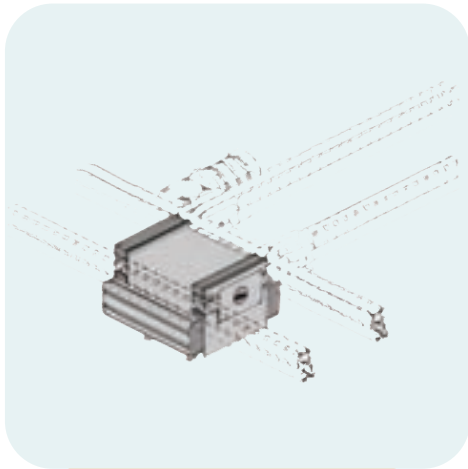

LIFT & TRANSVERSE UNIT

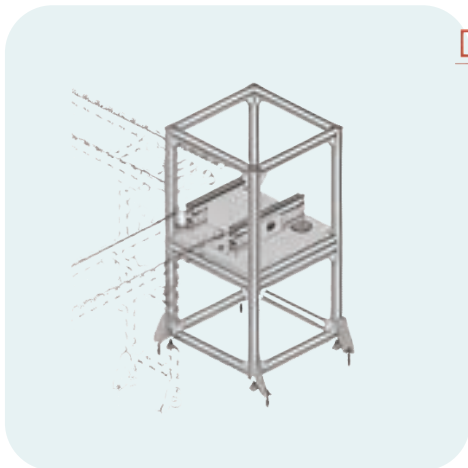

ROTATE UNIT

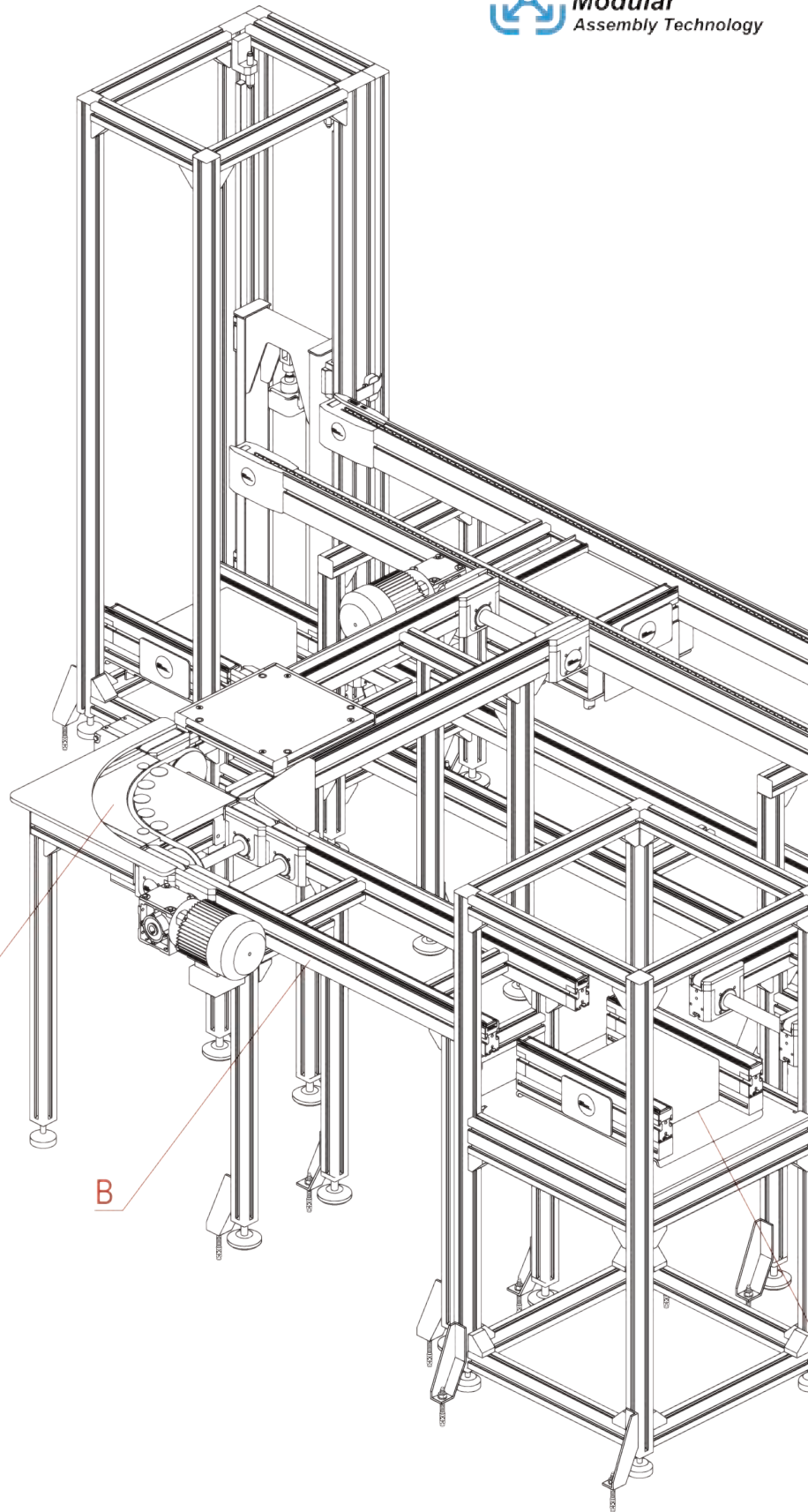

PALLET TRANSFER SYSTEM - OVERVIEW

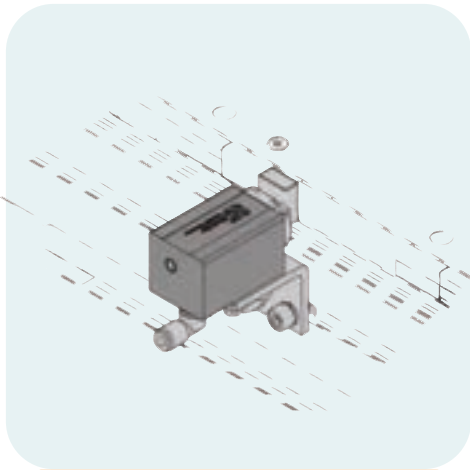

CONVEYING CONTROL DEVICE

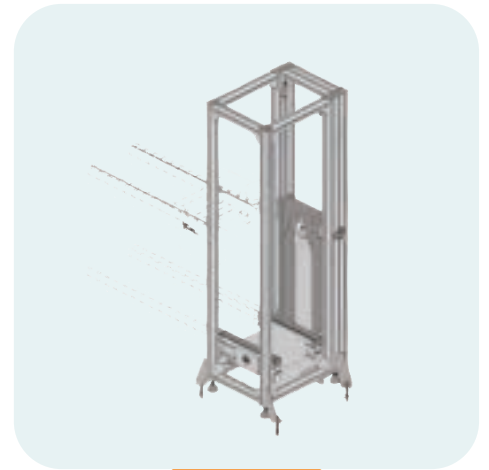

LIFT UNIT

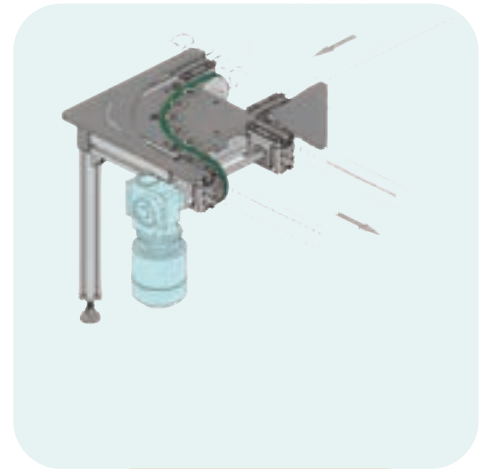
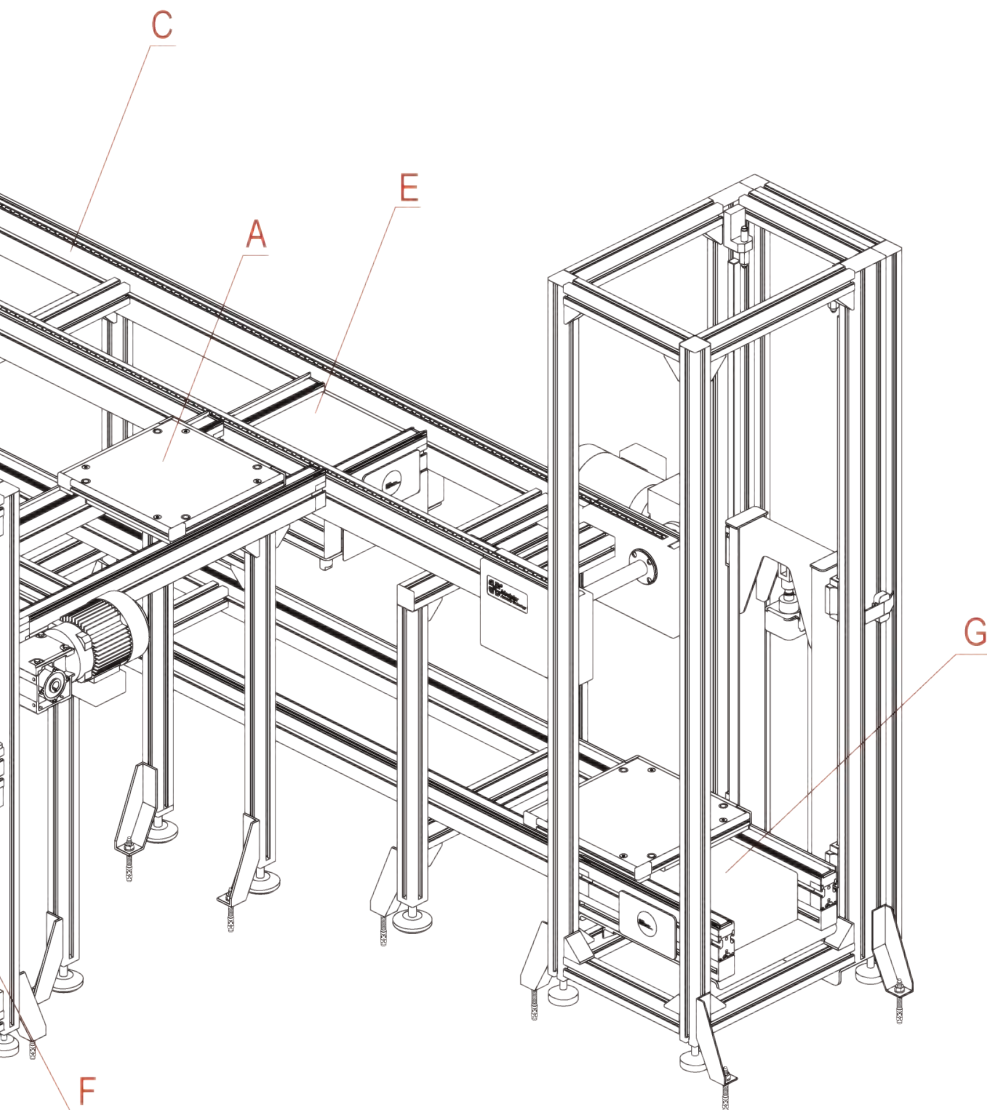

ROUND BELT CURVE

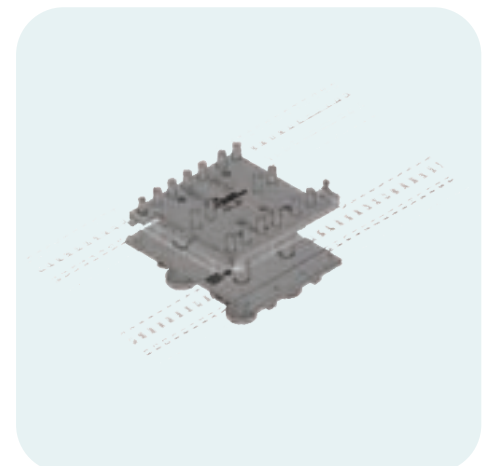

LIFT AND POSITIONING UNIT

A	Pallet	
B	PTS1 & PTS1/H Pallet Conveyor	PTS1 & PTS1/H
C	PTS2 Pallet Conveyor	PTS2
D	PCU90 Round Belt Curve	PCU90
E	PLT60 Lift and Transverse Unit	PLT60
F	PRO30 Rotate Unit	PRO30
G	PLI60 Lift Unit	PLI60

PTS1 & PTS1/H & PTS2 Pallet System

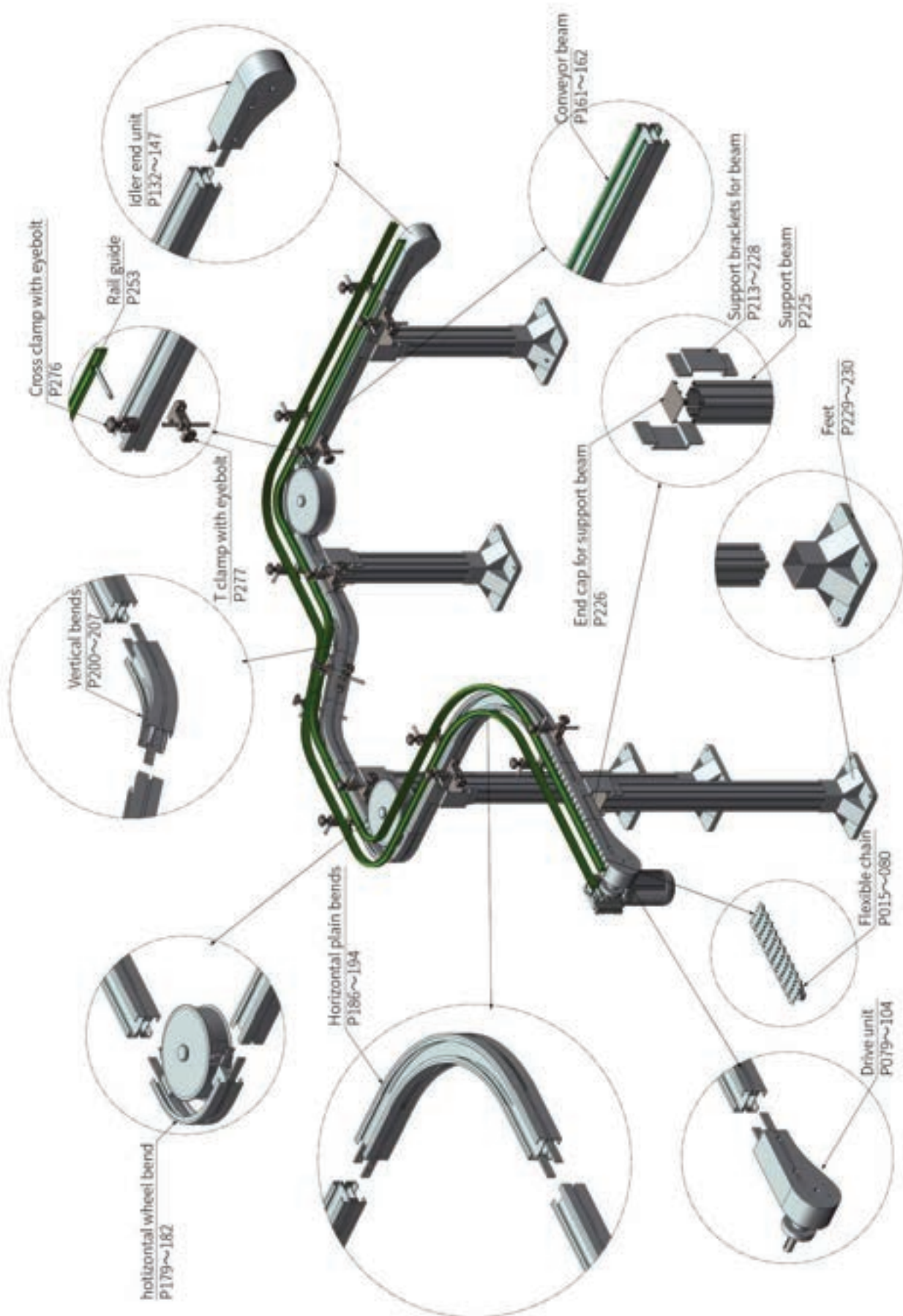

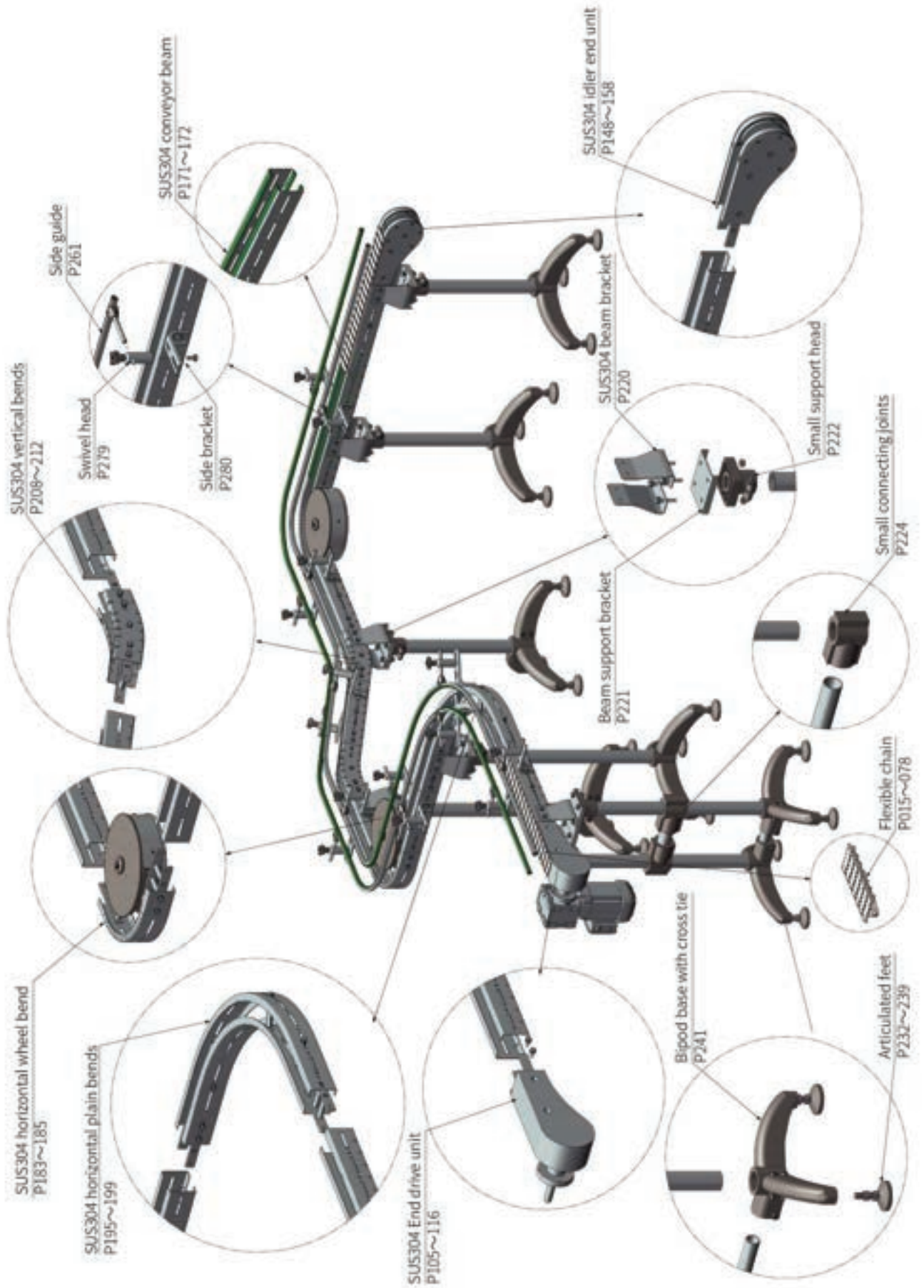

Flexible Chain Conveyors help move assemblies up, down and around. Flexible chain conveyors, like the iConMov system, are a great alternative for transporting small assemblies or moving larger objects over complex routes or through limited-space environments. This conveyor system is available in a basic aluminium version and a stainless steel model for applications with higher hygienic demands.



FLEXIBLE SPIRAL CONVEYOR

- Small footprint and can go up or down.
- Max weight of handling material: 2 kg per unit.
- It is not allowed to transport in forward end reverse directions.
- Max speed 40 meter per minute.



FLEX INCLINED CONVEYOR

- Suitable for complex layout requirements, can achieve multi-turning, multi-climbing conveying.
- Up to 30 kg/m.
- Irreversible.
- Max speed 40 meter per minute.

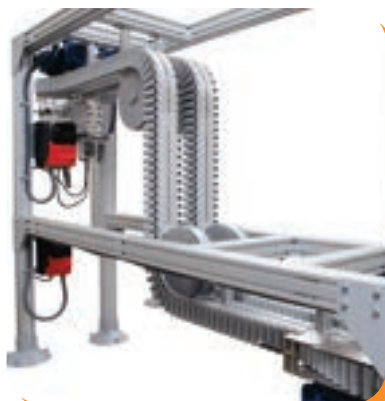

WEDGE GRIPPER CONVEYOR

- Designed to handle trays, bags, crates, bottles go up or down.
- Max weight of handling material: 1 kg per unit.
- Irreversible.
- Max speed 40 meter per minute.

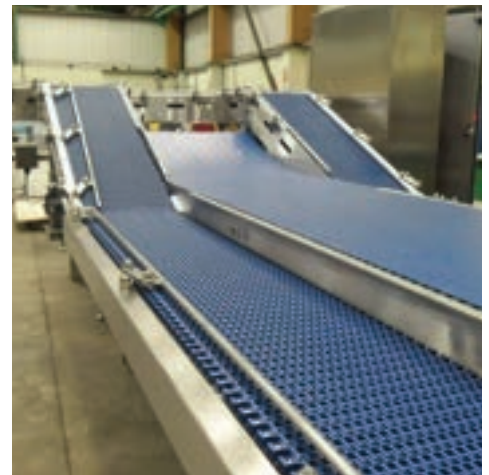
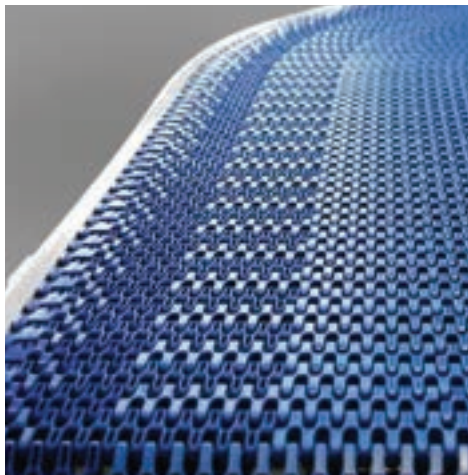
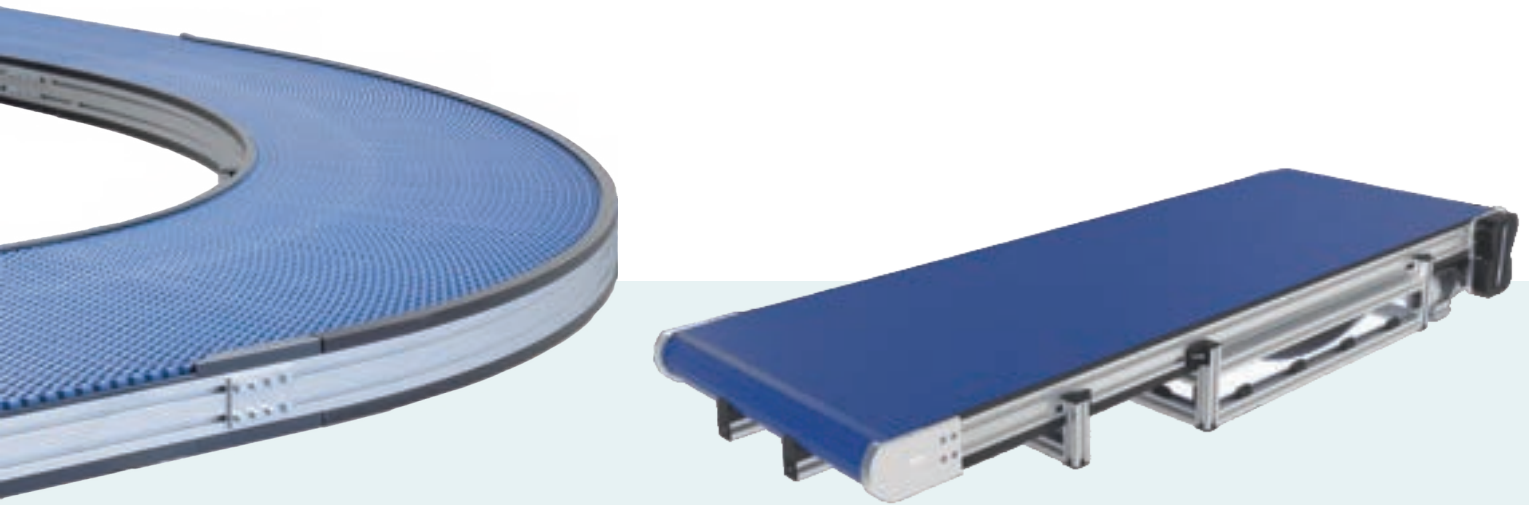

Modular belt conveyors are a middle ground between belt conveyors and chain conveyors. A modular belt consists of individual plastic modules usually linked together with joint rods. This modular belt is driven by chain sprockets; the base frame of the conveyor is constructed on standard profile supports. The modular belt makes it possible to accept hot workpieces or workpieces with sharp edges. Furthermore, large conveyor widths can be implemented without high pre-tensioning of the belts. However, in contrast to chain conveyors, this design is less maintain-intensive and is a technically simpler solution. These systems are frequently used as cooling lines, since the chain modules can be designed to be permeable to air.



A belt conveyor is an endless belt operation between two pulleys with its load supported on the idlers. The belt helps transport material from one place to another during a production process. iConMov focuses on building standard belt conveyors suitable to various application requirements.



Powered roller conveyors take less effort to move loads than unpowered (gravity-flow) roller conveyors. They convey items at a controlled speed with even spacing and are typically used in warehousing, manufacturing, package handling, and distribution applications. Roller conveyors are normally used in environments such as warehouses or manufacturing facilities due to the nature of transporting goods. Using a roller conveyor can add versatility to the type of transfers, diverters, and stops that can be used as part of a conveyor system or automation system. You can get roller conveyors in mild steel, galvanized, plastic, or stainless steel.



Seamless Transitions, Maximum Productivity
Conveyor Solutions Experts

www.iconmov.in



SCAN TO
DOWNLOAD
THIS
BROCHURE

✉ sales1@iconmov.in
sales2@iconmov.in

iConMov Technologies Pvt Ltd

📍 Plot no-37, GAT no-714, Jayawant Industrial Estate,
Pune-Bangalore Highway, Pune-412206